

## MÉRETEK

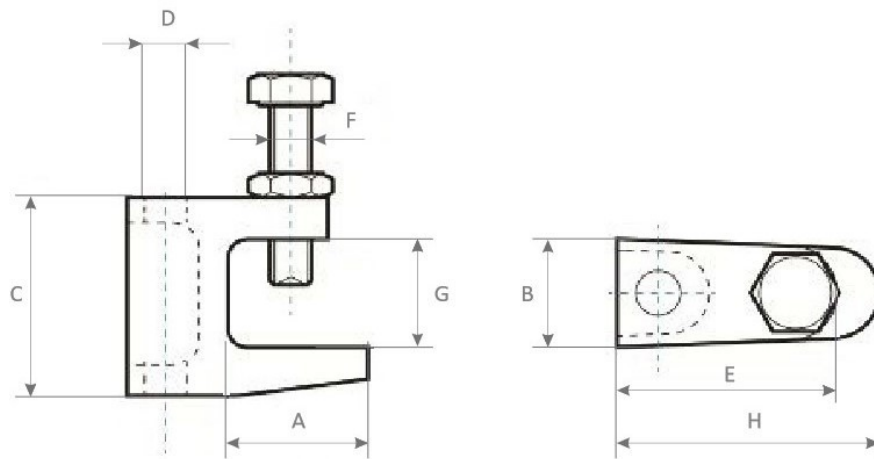

	A [mm]	B [mm]	C [mm]	D [mm]	E [mm]	F [mm]	G [mm]	H [mm]	Max. terhelés [kg]
<b>CCL M6</b>	21	18	35	M6	35	M6	18	38	80
<b>CCL M8</b>	21	19	35	M8	35	M8	18	38	120
<b>CCL M10</b>	23	21	42	M10	41	M10	20	40	250

## BEÉPÍTÉSI JAVASLAT

